

FREESTANDERS

Freestanders extends the benefits of our cable and rod display systems by adding a strong, but lightweight, aluminium framework that can be used freestanding or fixed to a wall. Its eye-catching elliptical profiles have been designed to combine strong aesthetic appeal with a versatile display capability that is also exceptionally price competitive. Users can choose the shelves, pockets, holders, dispensers and lighting required to complete their display from the extensive range shown in this guide.

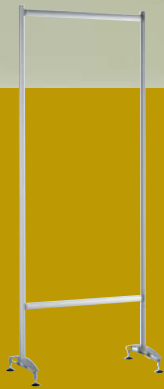

HAVE YOU THOUGHT ABOUT ADDING LIGHTING TO YOUR DISPLAY?

FREESTANDERS

Single bay freestanding frame

Supplied with freestanding feet.

Part no.	Internal width	Overall height
E4101	550mm	2050mm
E4102	700mm	2050mm
E4103	850mm	2050mm
E4104	1000mm	2050mm
E4105	1250mm	2050mm
E4106	1500mm	2050mm

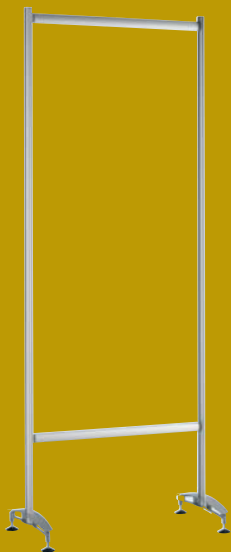

Freestanding extension bay

Supplied with freestanding foot.

Part no.	Internal width	Overall height
E4107	550mm	2050mm
E4108	700mm	2050mm
E4109	850mm	2050mm
E4110	1000mm	2050mm
E4111	1250mm	2050mm
E4112	1500mm	2050mm

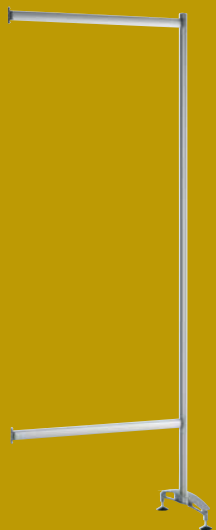

* See 1.5mm cable range
 ** See acrylic fabrication

Freestanding foot with castors

Part No. E4702



Freestanding flat base

Part No. E4703



Freestanding adjustable foot

Part No. E4701



Adjustable foot

Part No. E4023



Foot (for use with lighting)

Part No. E4005



1.5mm cable track kit

Part No: 6040/SA

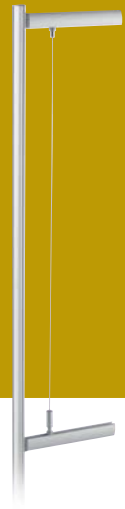

1.5mm cable shelf kit

Part No: E4401

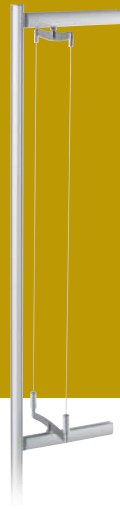

6.0mm rod track kit

Part No: E4406

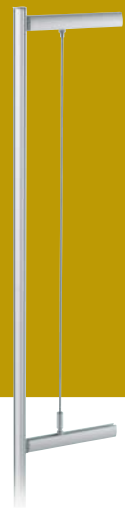

6.0mm rod shelf kit

Part No: E4402

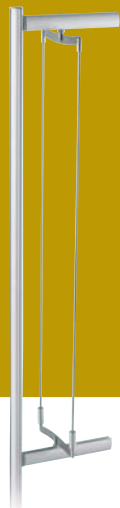

Freestanding Unipost

4 prong

Part No. E4301

Oval

Part No. E4302

Overall height 2M.



Four prong base for freestanding Unipost

Part No. E4006



Oval base for freestanding Unipost

Part No. E4007



Floor to ceiling upright kit complete

Part No. E4015

3M length of vertical extrusion complete with adjustable foot top and bottom.

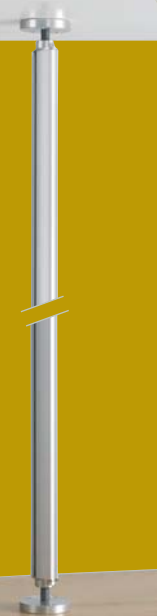

Vertical extrusion

Part No. E4710 (6000mm)
Part No. E4705 (3000mm)



Joint assembly – upright to cross rail (pair)

Part No. E4800



Direct fix panel grip

Part No: E4040
For up to 8mm panel thickness.



Wall extensions

Part No. E4019 (75mm)
Part No. E4003 (200mm)



Cross rail extrusion

Part No. E4720 (6000mm)
Part No. E4715 (3000mm)



Vertical extrusion clamp

Part No: E4016
19mm ø button.
Panels will require 6mm ø holes.



Direct fix shelf kit (pair)

Part No: E4501
For up to 8mm panel thickness.



12V lighting 300mm arm

Part No. E4601



Plastic end cap for vertical extrusion

Part No. E4022



Transformer housing

Part No. E4602

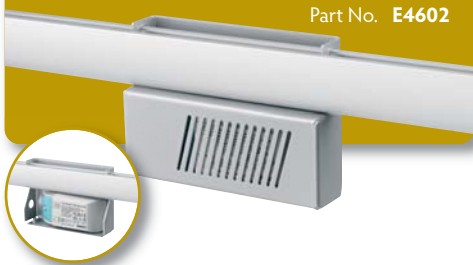

Powder coated option

Wide range of RAL and BS colour options available.



COMPONENT CUTTING GUIDES

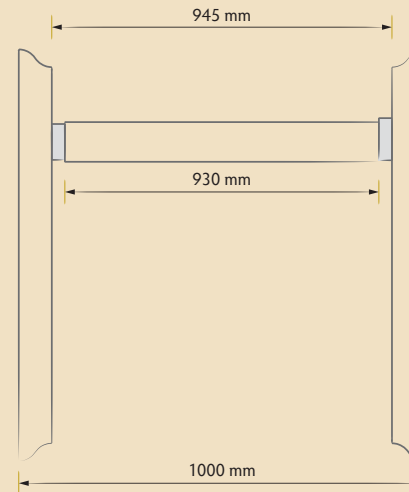

Cutting guide for horizontal extrusion bar for non-standard sized frames

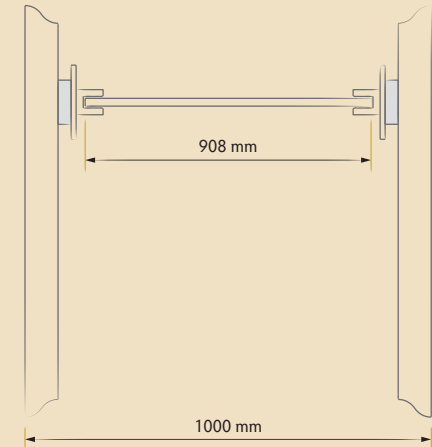

Cutting guide for shelves using direct shelf kit

Other Albion display products brochures in this series



-  Sign Connections sign fixings
-  1.5mm cable kits and components
-  3mm cable kits and components
-  6mm rod kits and components
-  10mm rod kits and components
-  Acrylic fabrication - pockets, dispensers etc
-  Cable and rod sample case
-  Starburst colourful components
-  LightStyle display lighting products
-  Frameless display system
-  Easi Fix sign and display system
-  Elements sign and cable kits for the trade
-  Custom fabrication service



Albion

ALWAYS MORE IN STORE

Albion Design & Fabrication Limited

Units 4-16 Gosforth Close Middlefield Industrial Estate Sandy Bedfordshire UK SG19 1RB
Telephone +44 (0) 1767 692313 Fax +44 (0) 1767 683157 info@albion-manufacturing.com www.albion-manufacturing.com